

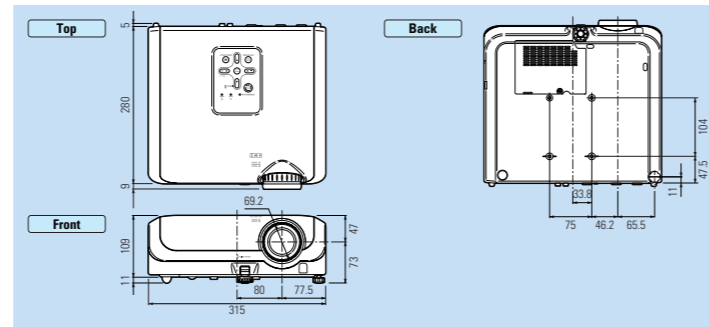





XG-MB67X



Dimensions (Units: mm)

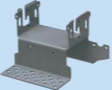

Optional Accessories

Lamp	USB Remote Receiver	Cable	Ceiling Mounts
 <b>AN-XR20LP</b>	 <b>AN-MR2</b>	 <b>AN-C3CP2</b> 3-RCA to 15-pin D-sub cable (3 m)	 <b>AN-TK201</b> For high ceiling installation
			 <b>AN-TK202</b> For standard ceiling installation
			 <b>AN-60TK</b> Installation adaptor

Note: Some of the optional accessories may not be available depending on the region. Please check with your nearest Sharp Authorized Projector Dealer or Service Center.

Specifications

Model	XG-MB67X
Panels	0.55" DMD
Number of pixels	786,432 (1,024 x 768)
Resolution	600 TV lines (DTV 720P input)
RGB input signals	SXGA+/SXGA/Mac 21" (in intelligent compression), XGA, SVGA, VGA, PC-98, VESA, Mac 19"/16"/13" 15-70 kHz (horizontal), 45-85 Hz (vertical), 12-108 MHz (pixel clock) (plug & play VESA: DDC 1/2B)
Video colour systems	NTSC 3.58/NTSC 4.43/PAL/PAL (60Hz)/PAL-M/PAL-N/SECAM DTV (480i/480P/540P/576i/576P/720P/1035i/1080i)
Lens	1:1.15 manual zoom and focus
Projection size	40" (102 cm) to 300" (762 cm) diagonal [Normal Mode (4:3)]
Projection distance	40" (102 cm): 1.4 - 1.6 m, 100" (254 cm): 3.5 - 4.0 m, 300" (762 cm): 10.4 - 12.1 m
Luminance	3,000 ANSI lumen (Standard Mode) 2,400 ANSI lumen (Low Power Mode)
Contrast ratio	2000:1
Audio amplifiers	2 W (mono)
Speakers	4 x 2.85 cm (oval) x 1
Input terminals	Computer RGB/component x 2 (15-pin mini D-sub), video x 1 (RCA), S-video x 1 (4-pin mini DIN), audio x 2 (3.5-mm mini jack x 1, RCA L/R), RS-232C serial x 1 (9-pin mini DIN), LAN x 1 (RJ-45)
Output terminals	Computer RGB/component x 1 (15-pin mini D-sub), audio x 1 (3.5-mm stereo mini jack)
Power source	AC 110-240 V, 50/60 Hz (Multi-Voltage)
Power consumption	385 W (Standard Mode), 308 W (Low Power Mode), 9.3 W (Standby) with AC 110 V 367 W (Standard Mode), 300 W (Low Power Mode), 10 W (Standby) with AC 240 V
Heat dissipation	1,450 BTU/hour (Standard Mode), 1,160 BTU/hour (Low Power Mode) with AC 110 V 1,380 BTU/hour (Standard Mode), 1,130 BTU/hour (Low Power Mode) with AC 240 V
Fan noise	37 dB (Standard Mode), 30 dB (Low Power Mode)
Projection lamp	300 W SHP
Lamp life*1	2,000 hours (Standard Mode), 3,000 hours (Low Power Mode)
Dimensions (W x H x D)	315 x 109 x 280 mm (main body only) 315 x 120 x 294 mm (including adjuster legs and projecting parts)
Weight	3.9 kg
Supplied accessories	Remote control, Two R-6 batteries (AA size, UM/SUM-3, HP-7 or similar), RGB cable (3.0 m), Lens cap, Power cord (1.8 m), DIN-D-sub RS-232C adaptor (15 cm), Operation manual

Design and specifications are current as of July 2006, but are subject to change without notice.  
 \* DLP® and the DLP logo are registered trademarks of Texas Instruments.  
 \* All company and/or product names are trademarks and/or registered trademarks of their respective manufacturers.  
 Sharp makes no warranties or representations of any kind with respect to these products.  
 \*1 The lamp life may vary depending on the usage condition.

SHARP

XG-MB67X  
True XGA Multimedia Projector



High-Quality, High-Performance DLP® Projector Includes Unique Network System for Convenient Management and Maintenance



TrueVision™

SHARP  
SHARP CORPORATION OSAKA, JAPAN  
URL <http://www.sharp-world.com/>

# Simple-to-Use New DLP® Projector with High-Contrast, High-Brightness and High-Quality Performance Reliability to Meet Your Needs

## High-Performance Projection Elements

### 3000 ANSI Lumen High Brightness (Standard Mode)

Sharp's advanced optoelectronics technology maximizes light output, providing crystal clear images in amazingly high brightness.

### Low Fan Noise

The DLP® high-speed colour wheel with non-contact Fluid Dynamic Bearings together with multiple ultra-quiet cooling fans reduce unpleasant noise, enabling quiet operation at 30dB in Low Power mode. The operation is so quiet it causes no disturbance even in meetings or school classes.

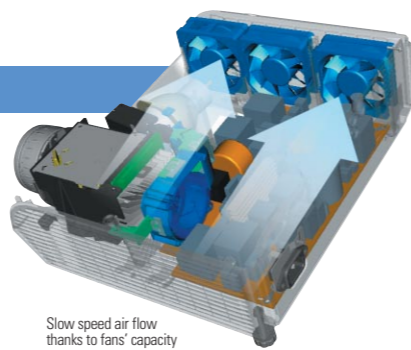

Slow speed air flow thanks to fans' capacity

## Cutting Edge Technology Provides High-Quality Picture

### 2000:1 High-Contrast, High-Quality Image

By utilizing the DLP® optical system and Sharp's optical technology, the projectors produce crisp details and sharper blacks in black parts thanks to a 2000:1 high contrast ratio.

#### Comparison of Contrast Ratio



XG-MB67X

### DLP® Digital Image

Using DLP® chip, each pixel is individually composed of one of over a half a million micromirrors to produce a high resolution, and the micromirrors lie at a distance of merely one micron, providing a seamless finely detailed picture. Also, high-speed on/off switching delivers smooth moving scenes.

#### High-Resolution Seamless Image Comparison

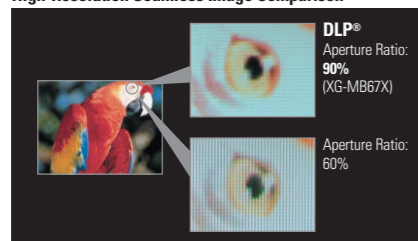

## High-Quality Reliability

### Long-Life High-Performance DLP® Picture

With DLP® technology minimally absorbing high-output light, the projectors maintain uniform colour reproduction capability for a long period of time. Also, DLP® chip formation with finely structured mirrors provides stable performance and delivers high-quality pictures for longer periods. The DLP® chip contributes to a long lifespan.

In addition, because there is no burn-in or remaining afterimage, the projectors are ideal for still picture projection such as for guidance board applications and projecting CAD images.

#### DLP® projection

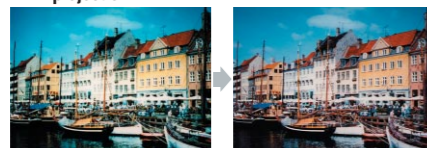

After 4,100 hours (The picture shows no significant deterioration even after using the DLP® panel 4,100 hours.)

\* By RIT/Munsell Colour Science Laboratory Test

### 3x Speed Colour Wheel

The projectors employ a colour wheel with an engine speed of up to 3x, improving colour break-up to an invisible level. Also, the non-contact Fluid Dynamic Bearings for the high-speed rotating colour wheel axle have a longer lifespan.

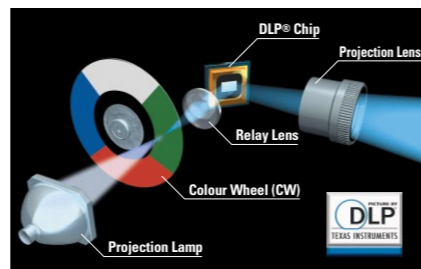

### IP Conversion from TrueVision™ Image Processing

TrueVision™ Image Processing provides optimal video performance. The motion-adaptive scan images produce smooth moving scenes and ensure smooth natural lines and edges.



### Double Sealed Mechanism

The optical mechanism is sealed in its structure, preventing dust, dirt and smoke from entering core parts of the optics to a much greater degree. Plus, filters have been added for an enhanced interactive combination to even further block entry of these elements.

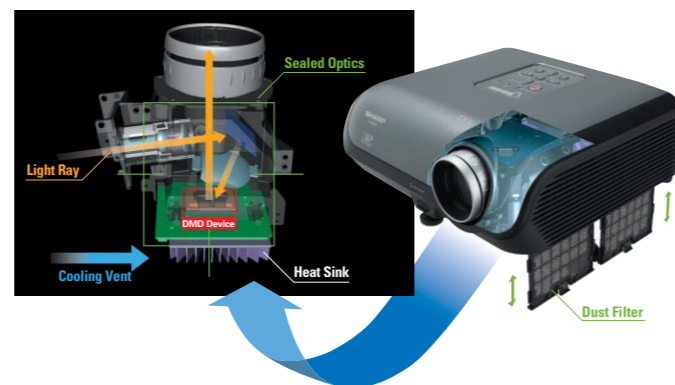

## Operation Simple Enough for Anyone to Use

### Setup Guide for Interactive Operation

The XG-MB67X Setup Guide provides intuitive OSD images to show the next step interactively for setup including focus, zoom and height adjustment.

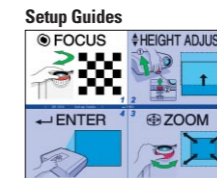

Setup guide is displayed after the projector is turned on.

### Interactive Help Menu

The Help Menu displays any problems and assists the user in solving problems with operation.

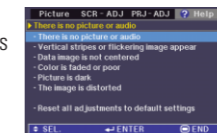

### Advanced Picture Mode

Quickly and directly choose the appropriate settings for the picture mode and lamp brightness to match the intended application.



"Picture Mode" triggers on the Menu and the remote control.



Intuitive Button Layout

### Universal Design

The beeping sound informs the user when the power is on and cooling down has completed. Also, intuitive button layout allows the user to operate the projector simply.

### Quick Start

It takes only approx. 3 seconds to project the image.

## Multiple Connections for a Wide Range of Applications

### Multiple Input Terminals

Projectors can be connected to DVD players, cable or satellite boxes, laptop and desktop computers, HDTV tuners, VCRs and video game consoles.



## Sharp Unique Network System

### Web Browser Control

Web browser control enables remote access and management of the projector by utilizing built-in firmware without the need for additional special software.

### Remote Access for Control and Adjustment

Projector control functions, including power on, input select, volume, and AV mute as well as projector settings can be controlled and adjusted using a computer even in another room.

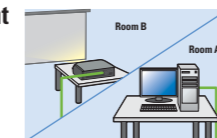

### Diagnosis and Auto Email Sending

Email is automatically sent to appointed addresses when detecting an error, such as the lamp going out, unusual heating or cooling fan breakdown.

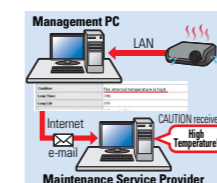

### Link to a Specific Website for Service and Support

Specific websites addresses, such as for service and maintenance companies, can be saved to be displayed on the screen of a connected computer if an error occurs with the projector. For example, the web address of a lamp vendor can be saved so that the site can be accessed with the displayed link if the lamp burns out, thereby enabling the user to directly purchase a replacement. The display can also show the phone numbers, messages and e-mail addresses.



### Control with Downloadable Display Manager

A greater variety of network projector control options can be used when the Sharp Display Manager\* is installed on the main computer. \* Sharp Display Manager can be downloaded from the Sharp Global Home Page for free. Sharp global homepage URL: <http://sharp-world.com/projector>

### Remote Access for Multiple and Group Projector Control

A management computer can control multiple projectors simultaneously.



### Periodic Error Diagnosis and Auto Email Sending

The Display Manager sends error messages and periodic reports.

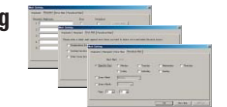

### Theft Detection and Message

A warning message will appear on the screen of a computer when projector cables are disconnected.



### PJLink™ Capability

The XG-MB67X is compatible with devices that support PJLink™, enabling systems to be easily built for centralized management and operation using a controller. For additional information about the PJLink™, visit <http://pjlink.jbmia.or.jp/english/>

### Control System Compatibility

The XG-MB67X provides superior compatibility with various control systems such as Crestron, AMX and Extron.



## Other Outstanding Features

- 4:3 and 16:9 Aspect Ratios and HDTV/DTV and DVD Compatible (1080i, 1035i, 720P, 576P, 576i, 540P, 480P and 480i).
- Image Shift Function  
Images projected in 16 x 9 format can be vertically shifted for better viewing in limited spaces.
- Auto Keystone Correction
- Presentation Support: Freeze, AV Mute
- Theft Deterrent Function "System Lock"
- Key Lock Function

## Correlation of the Projector to the Screen

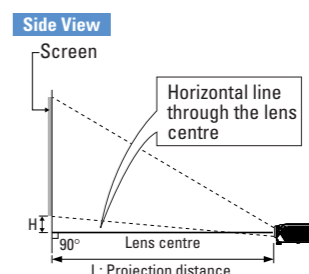

### Screen Size and Projection Distance

Picture size (inches)	Picture size (cm)			Projection distance (L) (cm)		Distance from lens centre to the bottom of the image (H) (cm)
	Width	Height	Minimum	Maximum		
300	610	457	10.4m	12.1m	48cm	
200	406	305	7.0m	8.1m	32cm	
100	203	152	3.5m	4.0m	16cm	
80	122	91	2.1m	2.4m	10cm	
40	61	45	1.0m	1.2m	5cm	

Picture size (inches)	Picture size (cm)			Projection distance (L) (cm)		Distance from lens centre to the bottom of the image (H) (cm)	Adjustable range of image position (S) (cm)
	Width	Height	Minimum	Maximum			
250	553	311	9.5m	11.0m	56cm	±52cm	
200	443	249	7.5m	8.8m	44cm	±42cm	
100	221	125	3.8m	4.4m	22cm	±21cm	
80	133	75	2.3m	2.6m	13cm	±12cm	
40	66	38	1.1m	1.3m	6.5cm	±6cm	

\* Negative figures mean the lens centre position is under the bottom of the picture.  
\* Allow a margin of error in the above values.