

SHARP

FO-5900

Laser Facsimile

A Speedy Facsimile to Streamline Your Office



Keep Your Business Moving at Top Speed

Combining innovative technology with rock-solid reliability, the SHARP FO-5900 Laser Facsimile is ready to meet the challenges of today's busy office. Powered by a speedy 16 ppm print engine, the FO-5900 provides 1.3-second quick scan, Super G3 modem technology, and a host of time-saving and user-friendly features. The FO-5900 also boasts a large, expandable paper supply and upgradeable flash memory to cover your every office need. The high-performance FO-5900 from SHARP – top-class functionality to keep your business moving at top speed.



Intuitive, Easy-to-Use Interface

Operation and programming on the FO-5900 is easy and predictable. With the large tilting status display and logically arranged keypad and menus, you will be an expert on the FO-5900 in minutes.

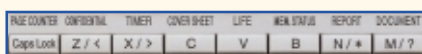

Flip open the one-touch rapid dial panel to access these function keys located underneath it.

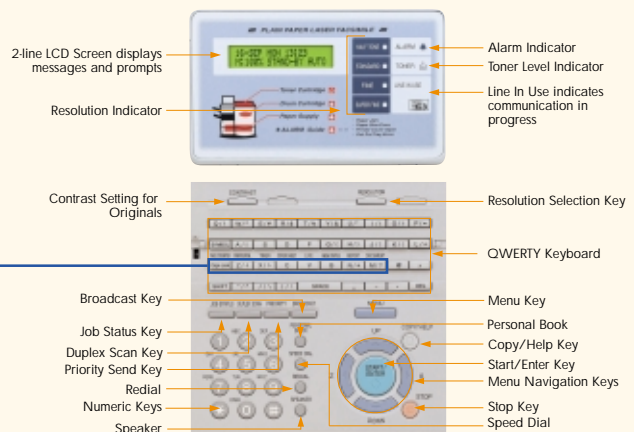

Get the Job Done Faster, Easier

FAST

1.3-Second Quick Scanning and Duplex Scan

With a scanning time of 1.3 seconds per page, Quick Scan keeps your documents from being tied up in the fax machine, saving you precious time. And, for further convenience, Duplex Scan rapidly scans two-sided documents and transmits the pages in the correct order – no more waiting by the machine to separate the pages.

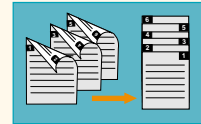

16 ppm High-Speed Printing

A printing speed of 16 pages per minute helps the FO-5900 get the job done faster. So, whether you're printing out faxes or using the FO-5900 as a back-up copier, your print jobs couldn't be easier.

Super G3 Modem for High-Speed Transmission

The FO-5900's 33.6 Kbps Super G3 Modem uses JBIG compression to transmit faxes at a speedy two seconds per page – because every second counts in today's fast-paced business world.



POWERFUL

Expandable Memory

To protect your documents in the event of a power failure, the FO-5900 comes with 2 MB of standard flash memory – giving storage of up to 125 pages*. You can even expand the memory to 10 MB, for efficient handling of large volume jobs (up to a maximum of 625 pages*).

* Based on Sharp's standard chart at standard resolution.

Large Paper Capacity

For heavy-duty fax reception, the standard 250-sheet paper capacity can be boosted to an impressive 750 sheets with the addition of the optional 500-sheet cassette. Installing this cassette also enables the 250-sheet main unit to provide a handy fax separator feature, which inserts a coloured paper sheet between received faxes for easy separation.



Optional 500-Sheet Cassette

Heavy-Duty Document Feeder

The 50-sheet Automatic Document Feeder offers the convenience of voluminous document handling. In tandem with Duplex Scan, it lets you scan up to 100 pages* at a time – so you're spared the inconvenience of manually inserting the original documents.

* Based on Sharp's standard chart at standard resolution.

EASY

Personal Auto-Dial Phone Books

In addition to **59 rapid dial** (one-touch) keys and **75 speed dial** (abbreviated) codes, the FO-5900 offers 10 personal auto-dial phone books that enable users to store up to 75 numbers per book – a total of 750 additional numbers. Busy offices that have several departments using the same FO-5900 can assign a personal auto-dial phone book to each of them. For your security, phone books are accessible by a Personal Identification Number.

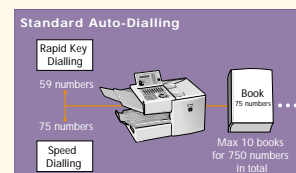

Easy-to-Read Tilted Status Display

The tilted status display gives you a wealth of information at a glance. Find out quickly about the fax transmission status, the paper supply, and the condition of the toner and drum cartridges.



- Help function
- Easy-to-operate navigation key
- QWERTY keyboard

Other Outstanding Features

- > Dual Access
- > Verification Stamp (optional)
- > Group Dialling—Up to 59 Groups/133 Locations
- > 64-Level Halftone
- > Chain Dialling
- > Anti-Junk Fax (50 locations)
- > Polling (154 locations)
- > Serial Broadcasting to 154 locations
- > Confidential Transmission/Reception (10 boxes)
- > Department Codes (30 departments)
- > Batch Transmission (59 locations)
- > Program Keys (up to 59)
- > Timer Communication (up to 59 jobs)

Specifications

Applicable Telephone Line:	Public Switched Telephone Network (PSTN)	Paper Stack Capacity:	200 sheets
Configuration:	Half-duplex desktop facsimile transceiver	Input Document Size:	Automatic feeding Width: 148 to 256mm (5.8" to 10.1") Length: 128 to 279mm (5.0" to 10.9")
Data Compression:	MH, MR, MMR, JBIG, H2 (Sharp special)		Manual feeding Width: 148 to 279mm (5.8" to 11.0") Length: 128 to 483mm (5.0" to 19.0")
Memory Size:	2 MB Flash Memory (approx. 125 pages) expandable to 10 MB (approx. 625 pages)*	Automatic Document Feeder:	50 sheets maximum
Modem speed:	33,600 to 2,400 bps automatic fallback*	Halftone (grayscale):	64 levels
Transmission Time:	Approx. 2 seconds per page*	Copy Function:	Single/Multi-copy/Sort-copy (up to 99 copies/page)
Scan Speed:	1.3 seconds per page	Power Requirements:	Rated local AC voltage and frequency
Print Speed:	16 pages per minute	Power Consumption:	220–230V: max. 820W, standby 10W 110V: max. 1,000W, standby 9W
Resolution:	Horizontal: 8 pels/mm (203 pels/inch) Vertical: 15.4 lines/mm (392 lines/inch)[Superfine] 7.7 lines/mm (196 lines/inch)[Fine/Halftone] 3.85 lines/mm (98 lines/inch)[Standard]	Dimensions (W x H x D):	546 x 346 x 412 mm 21.5" x 13.6" x 16.2"
Recording System:	Laser	Weight:	Approx. 12.6 kg (27.8 lbs.)
Reception Modes:	Auto/Manual	Accessories & Options:	500-sheet Paper Drawer: FO-59A4 8 MB Flash Memory: FO-8MK Verification Stamp: FO-45VS Toner Cartridge: FO-59DC Drum Cartridge: FO-47DR
Max. Document Width:	280mm (11.0")		
Max. Scanning Width:	210mm (8.3")		
Max. Recording Width:	203mm (8.0")		
Paper Capacity:	250 sheets expandable to 750 sheets		

Design and specifications subject to change without notice. Sharp is a registered trademark of Sharp Corporation. All other trademarks are property of their respective holders.

* Based on Sharp's standard chart at standard resolution.

■ Dimensions

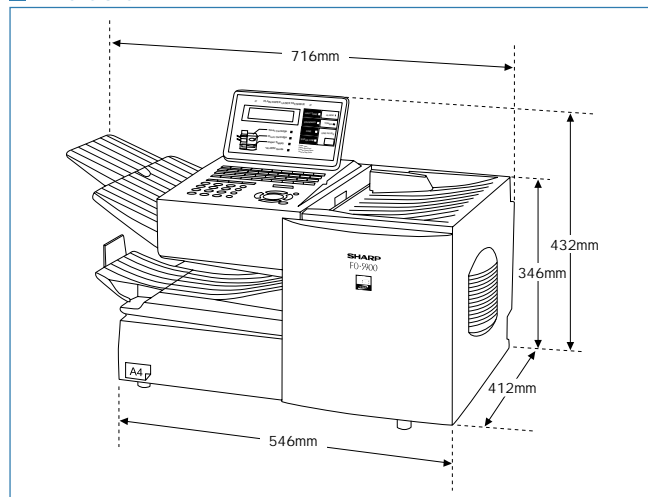

SHARP
SHARP CORPORATION OSAKA, JAPAN
<http://sharp-world.com/index.html>

Distributed by: